

TRP chain coupling, composed of two-strand roller chains and two sprockets, features simple and compact structure, and high flexibility, power transmission capability and durability. TRP chain coupling allows simple connection, disconnection and the use of the housing enhances safety and durability.

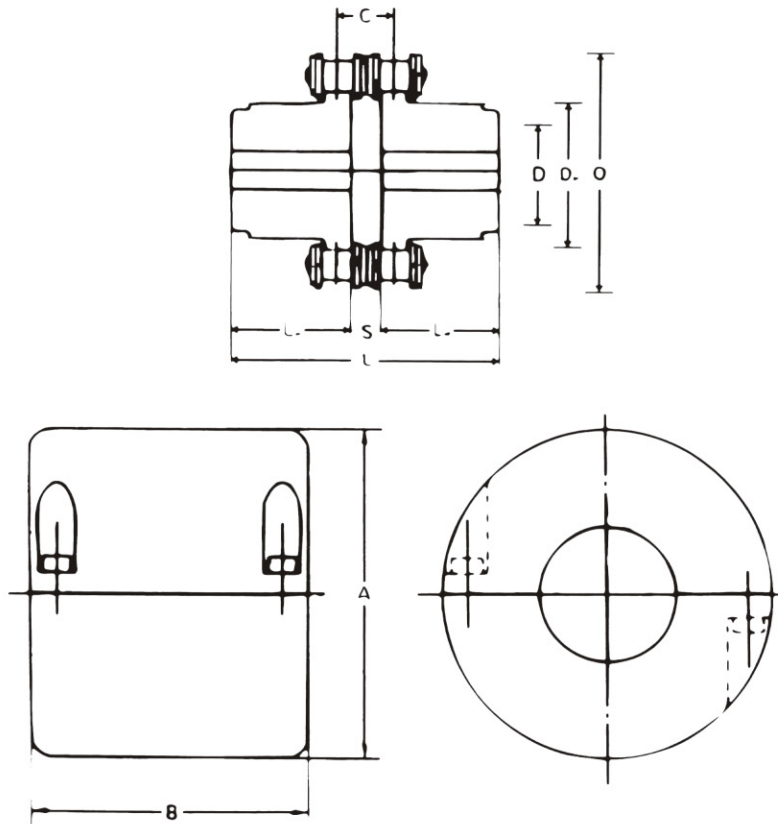

Casing

Make sure to use the housing for high-speed operation, and for use in dusty or corrosive environment.

Dimension: mm

Coupling No.	Chain Pitch	Stock Hole Dia.	Shaft Dia		O	L	DH	LH	S	C	Approx. WT (kg.)	A	B	Approx. WT (kg.)
			Min.	Max.										
3012	9.525	12	13.5	16	45	65	27.2	29.5	6.0	10.1	0.31	69	63	0.22
4012	12.70	12	14	22	62	79.4	36	36	7.4	14.4	0.73	77	72	0.30
4014		12	14	28	69	79.4	45	36			1.12	84	75	0.31
4016		13.5	16	32	77	87.4	51.5	40			1.50	92	72	0.35
5014	15.875	14.5	17	35	86	99.7	56	45	9.7	18.1	2.15	101	85	0.47
5016		14.5	18	40	96	99.7	64	45			2.75	110	87	0.50
5018		16	18	45	106	99.7	73.5	45			3.60	122	85	0.60
6018	19.05	20	22	56	127	123.5	89.5	56	11.5	22.8	6.55	147	105	1.2
6020		20	24	60	139	123.5	102.5	56			8.38	158	105	1.2
6022		20	28	71	151	123.5	115	56			10.4	168	117	1.2
8018	20.40	20	32	80	169	141.2	115	63	15.2	29.3	13.2	190	129	1.9
8020		20	36	90	185	145.2	125	65			16.2	210	137	2.5
8022		20	40	100	202	157.2	142	71			21.8	226	137	2.7
10020	31.75	25	45	110	233	178.8	162	80	18.8	35.8	32.4	281	153	4.1
12018	38.10	35	50	125	256	202.7	173	90	22.7	45.4	43.2	307	181	5.2
12022		35	56	140	304	222.7	213	100			69.1	357	181	6.7